

### Features

Designed for base station applications in the 1805-1880MHz or 1930-1990MHz Frequency Band. Suitable for GSM, EDGE, TDMA, CDMA, and multi-carrier amplifier applications

- 30W CW Output Power at  $P_{1dB}$
- 13dB Gain at  $P_{1dB}$
- 45% Drain Efficiency at  $P_{1dB}$
- 10:1 VSWR Ruggedness (CW @ 30W, 26V, 1900MHz)
- Internal input and output matching

### Package Style

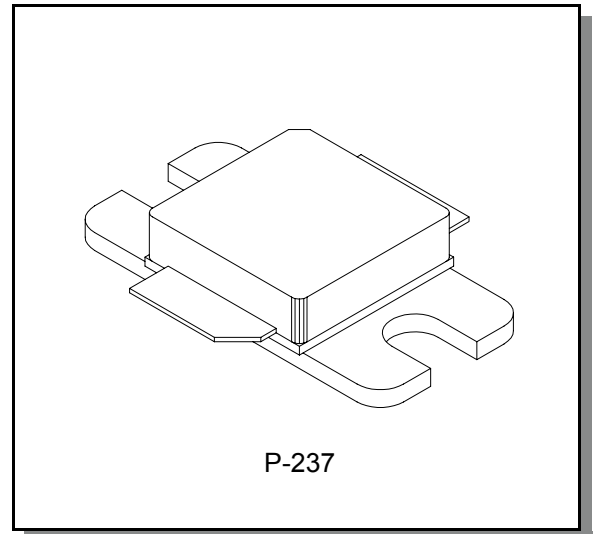

### Maximum Ratings

Parameter	Symbol	Rating	Units
Drain—Source Voltage	$V_{DSS}$	65	$V_{dc}$
Gate—Source Voltage	$V_{GS}$	20	$V_{dc}$
Drain Current — Continuous	$I_D$	10	$A_{dc}$
Total Power Dissipation @ $T_c = 25^\circ C$	$P_D$	97	W
Storage Temperature	$T_{STG}$	-40 to +150	$^\circ C$
Junction Temperature	$T_J$	+200	$^\circ C$

### Thermal Characteristics

Characteristic	Symbol	Max	Unit
Thermal Resistance, Junction to Case	$R_{\theta JC}$	1.8	$^\circ C/W$

**NOTE—CAUTION**—MOS devices are susceptible to damage from electrostatic charge. Precautions in handling and packaging MOS devices should be observed.

Preliminary

Characteristic	Symbol	Min	Typ	Max	Unit
<b>DC CHARACTERISTICS @ 25°C</b>					
Drain-Source Breakdown Voltage ( $V_{GS} = 0$ Vdc, $I_D = 20$ $\mu$ Adc)	$V_{(BR)DSS}$	65	—	—	Vdc
Zero Gate Voltage Drain Leakage Current ( $V_{DS} = 26$ Vdc, $V_{GS} = 0$ )	$I_{DSS}$	—	—	100	$\mu$ Adc
Gate—Source Leakage Current ( $V_{GS} = 5$ Vdc, $V_{DS} = 0$ )	$I_{GSS}$	—	—	1	$\mu$ Adc
Gate Threshold Voltage ( $V_{DS} = 10$ Vdc, $I_D = 20$ mA)	$V_{GS(th)}$	2	2.6	4	Vdc
Drain-Source On-Voltage ( $V_{GS} = 10$ Vdc, $I_D = 1$ A)	$V_{DS(on)}$	—	0.32	—	Vdc
Forward Transconductance ( $V_{GS} = 10$ Vdc, $I_D = 1$ A)	Gm	—	1.6	—	S
<b>DYNAMIC CHARACTERISTICS @ 25°C</b>					
Input Capacitance (Capacitance includes internal matching capacitors) ( $V_{DS} = 26$ Vdc, $V_{GS} = 0$ , $f = 1$ MHz)	$C_{iss}$	—	50	—	pF
Output Capacitance ( $V_{DS} = 26$ Vdc, $V_{GS} = 0$ , $f = 1$ MHz)	$C_{oss}$	—	32	—	pF
Reverse Transfer Capacitance ( $V_{DS} = 26$ Vdc, $V_{GS} = 0$ , $f = 1$ MHz)	$C_{rss}$	—	1.4	—	pF
<b>RF FUNCTIONAL TESTS @ 25°C (In M/A-COM Test Fixture)</b>					
Two-Tone Common-Source Amplifier Power Gain ( $V_{DS} = 26$ Vdc, $P_{OUT} = 30$ W PEP, $I_{DQ} = 300$ mA, $f_1 = 1990.0$ MHz, $f_2 = 1990.1$ MHz)	$G_{ps}$	12	13	—	dB
Two-Tone Drain Efficiency ( $V_{DS} = 26$ Vdc, $P_{OUT} = 30$ W PEP, $I_{DQ} = 300$ mA, $f_1 = 1990.0$ MHz, $f_2 = 1990.1$ MHz)	EFF ( $\eta$ )	—	33	—	%
Two-Tone Common-Source Amplifier Power Gain ( $V_{DS} = 26$ Vdc, $P_{OUT} = 30$ W PEP, $I_{DQ} = 300$ mA, $f_1 = 1990.0$ MHz, $f_2 = 1990.1$ MHz)	IMD	—	-30	—	dBc
Two-Tone Common-Source Amplifier Power Gain ( $V_{DS} = 26$ Vdc, $P_{OUT} = 30$ W PEP, $I_{DQ} = 300$ mA, $f_1 = 1930.0$ MHz, $f_2 = 1930.1$ MHz)	$G_{ps}$	12	13	—	dB
Two-Tone Drain Efficiency ( $V_{DS} = 26$ Vdc, $P_{OUT} = 30$ W PEP, $I_{DQ} = 300$ mA, $f_1 = 1930.0$ MHz, $f_2 = 1930.1$ MHz)	EFF ( $\eta$ )	—	33	—	%
Two-Tone Intermodulation Distortion ( $V_{DS} = 26$ Vdc, $P_{OUT} = 30$ W PEP, $I_{DQ} = 300$ mA, $f_1 = 1930.0$ MHz, $f_2 = 1930.1$ MHz)	IMD	—	-30	-28	dBc
Output VSWR Tolerance ( $V_{DD} = 26$ Vdc, $P_{OUT} = 30$ W, $I_{DQ} = 300$ mA, $f = 1900$ MHz, VSWR = 10:1, All Phase Angles at Frequency of Tests)	$\Psi$	No Degradation In Output Power Before and After Test			

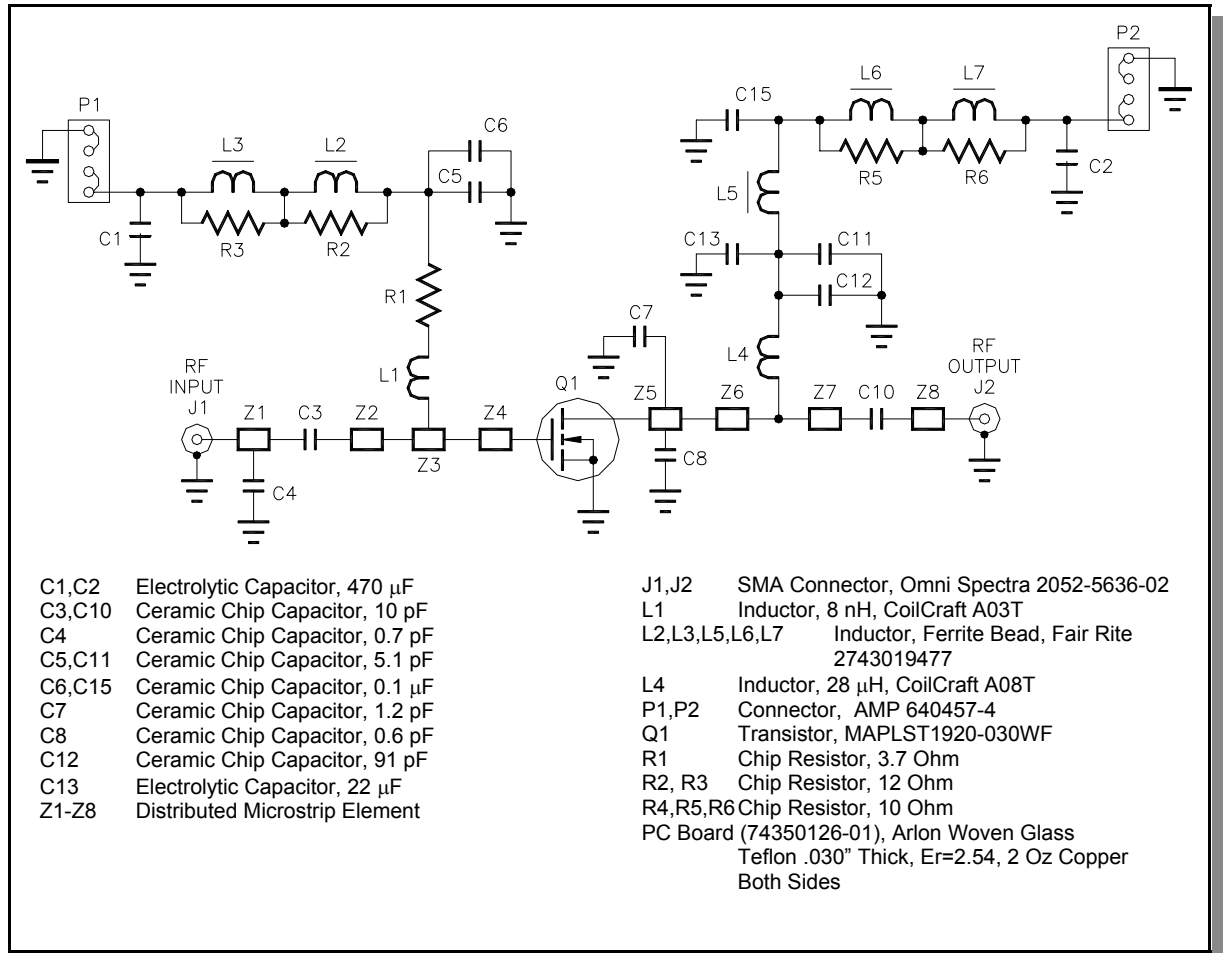

Figure 1. 1930—1990 MHz Test Fixture Schematic

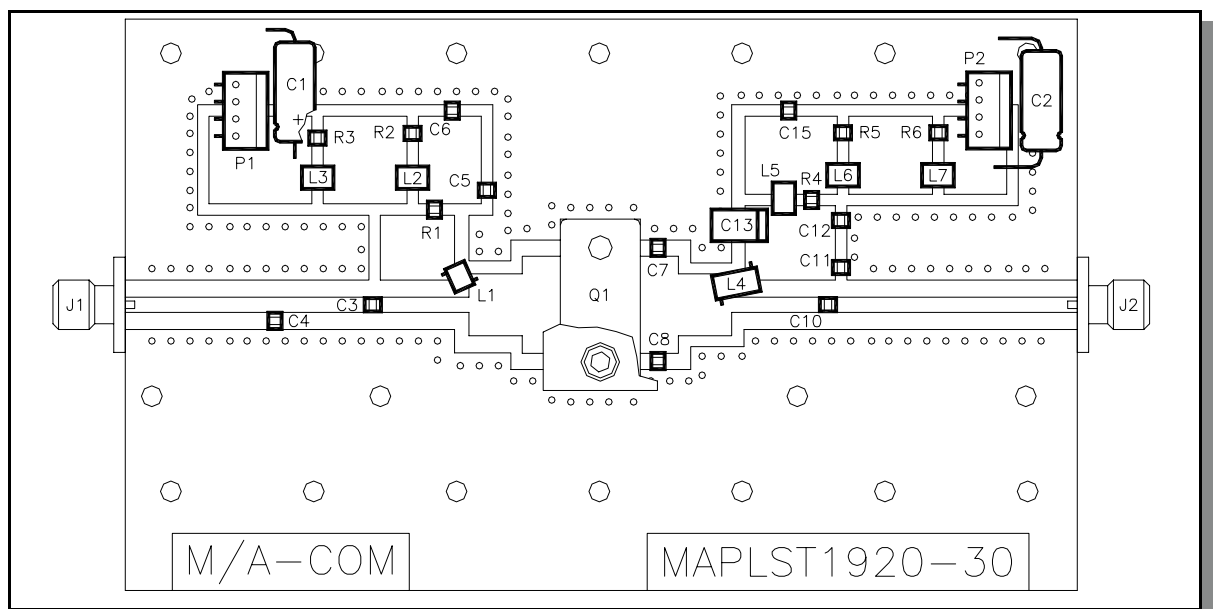
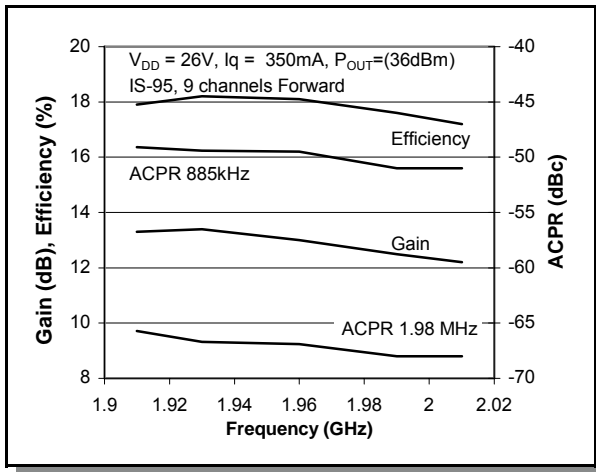
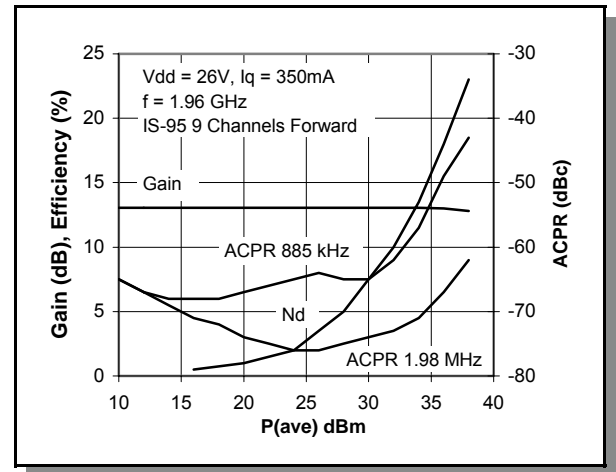

Figure 2. 1930—1990 MHz Test Fixture Component Layout



Graph 1. Class AB Broadband Circuit Performance



Graph 2. CDMA ACPR, Power Gain and Drain Efficiency vs. Output Power

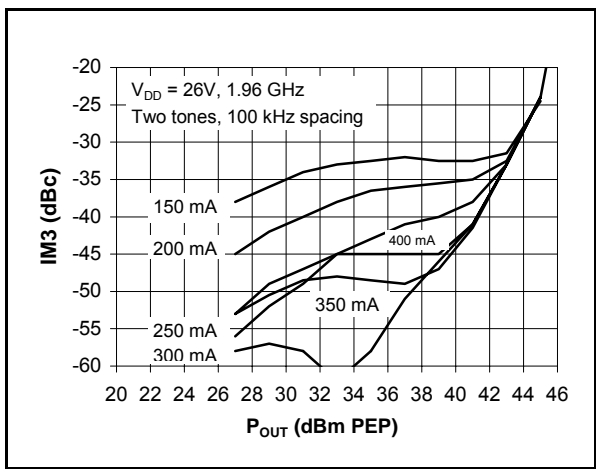

Graph 3. Intermodulation Distortion vs. Output Power

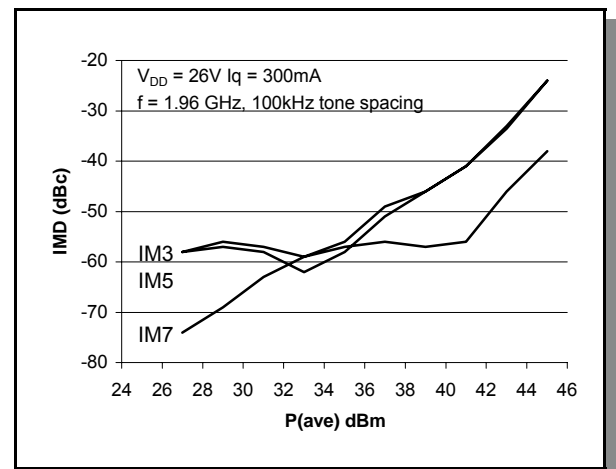

Graph 4. Intermodulation Distortion Products vs. Output Power

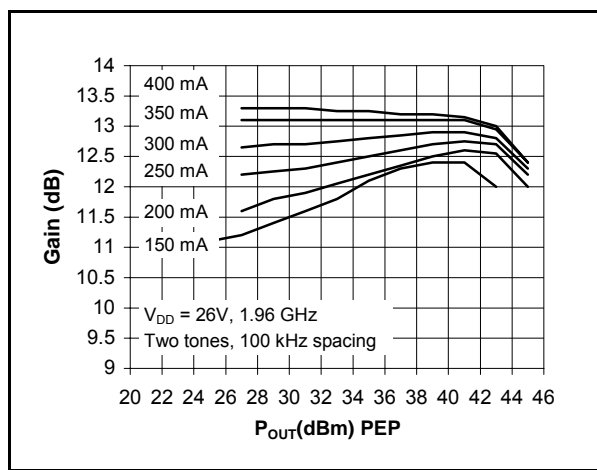

Graph 5. Power Gain versus Output Power

Package Dimensions

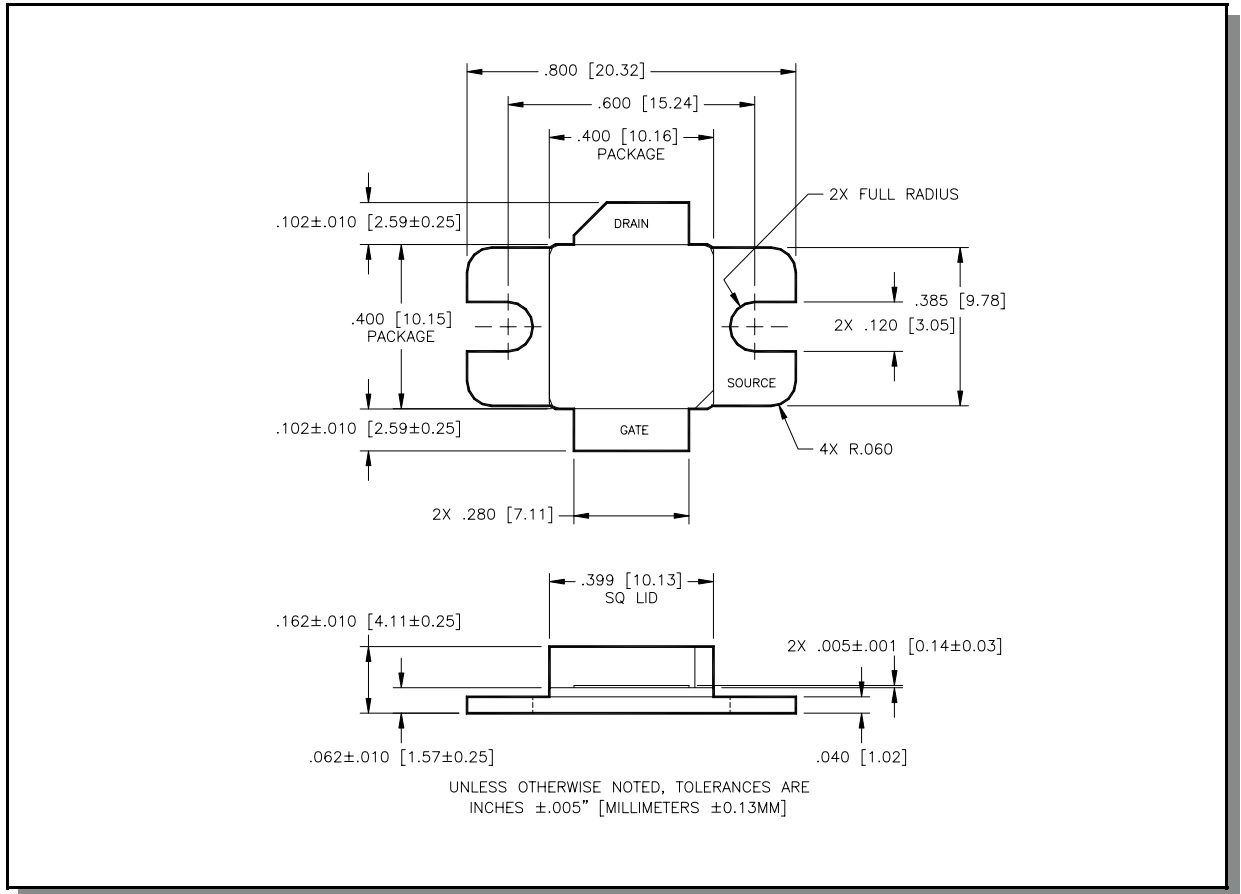

M/A-COM Inc. and its affiliates reserve the right to make changes to the product(s) or information contained herein without notice. M/A-COM makes no warranty, representation or guarantee regarding the suitability of its products for any particular purpose, nor does M/A-COM assume any liability whatsoever arising out of the use or application of any product(s) or information.

Visit [www.macom.com](http://www.macom.com) for additional data sheets and product information.

- North America: Tel. (800) 366-2266
- Asia/Pacific: Tel.+81-44-844-8296, Fax +81-44-844-8298
- Europe: Tel. +44 (1344) 869 595, Fax+44 (1344) 300 020

